

PC128UU-2

KOMATSU[®]

NET HORSEPOWER

64 kW 86 HP

OPERATING WEIGHT

13,400 - 13,770 kg **29,450 - 30,360 lb**



Photo shown includes optional equipment.

Hydraulics

- The PC128UU features the same HydraMind hydraulic system found on all other "Avance" Dash 6 excavators for greater control and smoother operation.

Cab Design

- A larger cab (43% in volume over the UU-1) allows the operator to work longer with less fatigue. AM/FM radio, air conditioner, and heater are now standard equipment for greater operator comfort and convenience.
- The sliding convex door facilitates entrance in confined work areas and reduces the danger of being damaged on roadways because the door does not protrude when open.

Automatic Height and Depth Stop

- Automatic stops are ideal for working in confined areas, such as overhead or buried power lines or restricted work areas.

Auto Attachment Safety Stop

- Allows the operator to focus on maximum attachment speed without concern of hitting the machine body.

Protected Hydraulics

- To avoid damage, attachment hoses are located inside the boom, and the cylinder has a guard.

Standard Dozer Blade

- The dozer blade allows easy backfill.

New Color—Natural Yellow

HYDRAULIC EXCAVATOR

PC128UU-2

SPECIFICATIONS



ENGINE

Model Komatsu S4D102E
 Type 4-cycle, water-cooled, direct injection
 Aspiration Turbocharged
 Number of cylinders 4
 Bore 102 mm **4.05"**
 Stroke 120 mm **4.76"**
 Piston displacement 3.92 ltr **239 in³**
 Flywheel horsepower
 (SAE J1349) 64 kW **86 HP** @ 2200 min⁻¹ **2200 rpm**
 Governor All-speed control, mechanical



HYDRAULIC SYSTEM

Type HydrauMind (Hydraulic Mechanical Intelligence New Design) system.
 Closed-center system with load-sensing valve and pressure-compensated valve.

Main pump:

Type Variable-capacity piston type
 Pumps for . . . Boom, arm, bucket, swing, blade, and travel circuits
 Maximum flow 226 ltr/min **59.7 U.S. gal/min**

Hydraulic motors:

Travel 2 x piston motor with parking brake
 Swing 1 x piston motor with swing holding brake

Relief valve setting:

Implement circuits 325 kg/cm² **4,620 psi**
 Travel circuit 355 kg/cm² **5,050 psi**
 Swing circuit 280 kg/cm² **3,980 psi**
 Boom offset 275 kg/cm² **3,910 psi**
 Blade 325 kg/cm² **4,620 psi**
 Pilot circuit 30 kg/cm² **430 psi**

Hydraulic cylinders:

(Number of cylinders – bore x stroke)
 Boom 2 – 105 mm x 1055 mm **4.1" x 41.5"**
 Arm 1 – 115 mm x 958 mm **4.5" x 37.7"**
 Bucket 1 – 90 mm x 885 mm **3.5" x 34.8"**
 Boom offset 1 – 130 mm x 346 mm **5.1" x 13.6"**
 Blade 2 – 115 mm x 181 mm **4.5" x 7.1"**



SWING SYSTEM

Driven by Hydraulic motor
 Swing reduction Planetary gear
 Swing circle lubrication Grease-bathed
 Swing lock Wet, multiple-disc brake
 Swing speed 10.0 rpm



DRIVES AND BRAKES

Steering control Two levers with pedals
 Drive method Fully hydrostatic
 Maximum drawbar pull 109 kN 11100 kg **24,470 lb**
 Maximum travel speed: High 4.6 km/h **2.9 mph**
 Low 3.2 km/h **2.0 mph**
 Service brake Hydraulic lock
 Parking brake Wet, multiple-disc



UNDERCARRIAGE

Center frame X-leg frame
 Track frame Box-section
 Seal of track Sealed track
 Track adjuster Hydraulic
 Number of shoes 42 each side
 Number of carrier rollers 1 each side
 Number of track rollers 7 each side



COOLANT AND LUBRICANT CAPACITY (REFILLING)

Fuel tank 200.0 ltr **52.8 U.S. gal**
 Radiator 18.2 ltr **4.8 U.S. gal**
 Engine 17.0 ltr **4.5 U.S. gal**
 Final drive, each side 2.5 ltr **0.7 U.S. gal**
 Swing drive 2.5 ltr **0.7 U.S. gal**
 Hydraulic tank 69.0 ltr **18.2 U.S. gal**



OPERATING WEIGHT (APPROXIMATE)

Operating weight, including 4290 mm **14'1"** offset boom, 2130 mm **7'0"** arm, SAE heaped 0.45 m³ **0.59 yd³** backhoe bucket, rated capacity of lubricants, coolant, full fuel tank, operator, and standard equipment.

Shoes	Operating Weight	Ground Pressure
500 mm 20"	13400 kg 29,540 lb	6.26 psi
600 mm 24"	13580 kg 29,940 lb	5.12 psi
700 mm 28"	13770 kg 30,360 lb	4.55 psi



DIMENSIONS

	Boom length	4290 mm	14'1"
	Arm length	2130 mm	7'0"
A	Overall length	7435 mm	24'5"
B	Overall height (to top of boom)	2560 mm	8'5"
C	Length on ground (transport)	7435 mm	24'5"
D	Overall width	2590 mm	8'6"
E	Overall height (to top of cab)	2730 mm	8'11"
F	Ground clearance, counterweight	855 mm	2'10"
G	Ground clearance (minimum)	390 mm	1'3"
H	Tail swing radius	1480 mm	4'10"
I	Track length on ground	2750 mm	9'0"
J	Track length	3480 mm	11'5"
K	Track gauge	1990 mm	6'6"
L	Width of crawler	2590 mm	8'6"
M	Shoe width	600 mm	23.6"
N	Grouser height	25 mm	1.0"
O	Upper structure height	1935 mm	6'4"
P	Upper structure width	2490 mm	8'2"
Q	Distance, swing center to blade end	2475 mm	8'1"
R	Blade width	2490 mm	8'2"
S	Blade height	590 mm	1'11"
T	Boom offset width (LH)	1170 mm	3'10"
U	Boom offset width (RH)	1150 mm	3'9"
V	Outside track digging width (LH)	130 mm	5.1"
W	Outside track digging width (RH)	550 mm	21.7"

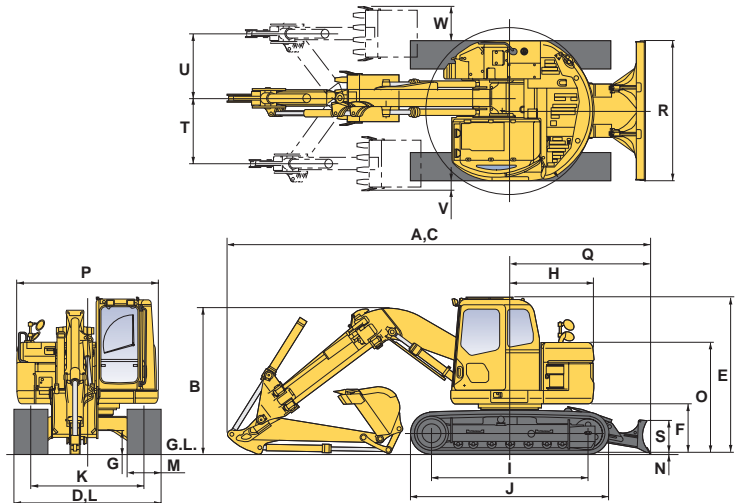

WORKING RANGE

	Boom	4290 mm	14'1"
	Arm	2130 mm	7'0"
A	Max. digging height	8150 mm	26'9"
B	Max. dumping height	5850 mm	19'2"
C	Max. digging depth	4865 mm	16'0"
D	Max. vertical wall digging depth	3305 mm	10'10"
E	Max. digging depth of cut for 8' level	4495 mm	14'9"
F	Max. digging reach	7285 mm	23'11"
G	Max. digging reach at ground level	7145 mm	23'5"
H	Min. swing radius*	1345 mm	4'5"
I	Blade max. lift above ground	465 mm	1'6"
J	Blade max. drop below ground	520 mm	1'8"
ISO	Bucket digging force	84.3 kN 8600 kg	18,960 lb
	Arm crowd force	58.8 kN 6000 kg	13,230 lb
SAE	Bucket digging force	73.5 kN 7500 kg	16,530 lb
	Arm crowd force	56.4 kN 5750 kg	12,680 lb

*When boom offset is zero

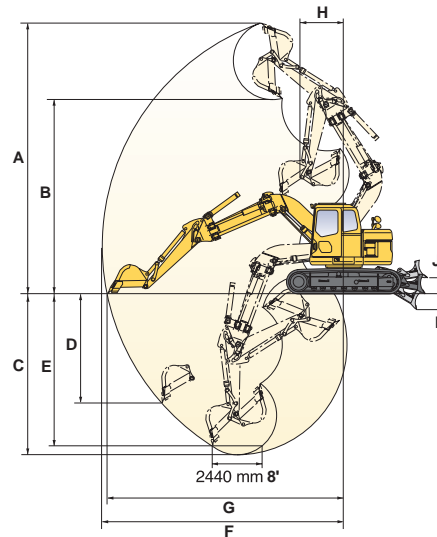

BACKHOE BUCKET AND ARM COMBINATION

Bucket Capacity (heaped)		Width				Weight		Number of Teeth	Arm Length
		With Side Cutters		Without Side Cutters					2130 mm 7'0"
SAE									
0.18 m ³	0.24 yd ³	450 mm	17.7"	570 mm	22.4"	256 kg	565 lb	3	○
0.28 m ³	0.38 yd ³	600 mm	23.6"	720 mm	28.3"	303 kg	670 lb	3	○
0.36 m ³	0.50 yd ³	700 mm	27.6"	820 mm	32.3"	330 kg	730 lb	4	○
0.45 m ³	0.59 yd ³	833 mm	32.8"	953 mm	37.5"	369 kg	810 lb	4	○
0.50 m ³	0.65 yd ³	859 mm	33.8"	979 mm	38.5"	399 kg	880 lb	4	□

○ – Used with weights up to 3,040 lb/yd³ □ – Used with weights up to 2,520 lb/yd³ X – Not recommended



STANDARD EQUIPMENT

- Air cleaner, double element with automatic dust evacuation
- Air conditioner
- Alternator, **24V**
- Arm, 2130 mm **7'0"**
- Blade assembly
- Batteries, 72Ah/2 x **12V**
- Boom holding valve
- Boom offset position setting
- Cab which includes: antenna, AM/FM radio, floormat, intermittent front windshield wiper and washer, large ceiling hatch, pull-up front window, removable lower windshield, openable rear window, sliding seat with **3"** seat belt
- Controls, wrist type
- Cooling fan, mixed flow with fan guard
- Corrosion resister
- Counterweight, 1880 kg **4,140 lb**
- Dustproof net for radiator and oil cooler
- Heater and air conditioner
- Instrument panel
- Lights, two top of cab front
- One-touch deceleration
- Pump/engine room partition cover
- Rearview mirrors, two
- Shoe, 500 mm **20"**, triple grouser
- Starting motor, 4.5 kW **24V**
- Travel alarm
- Turbocharger exhaust manifold cover
- Vandalism protection provision tabs
- Water separator



OPTIONAL EQUIPMENT

- Front window guard
- Head guard for cab
- Revolving frame undercover
- Service valve
- Shoes
 - 600 mm **24"** triple grouser
 - 700 mm **28"** triple grouser
 - 500 mm **20"** rubber pad



LIFTING CAPACITY

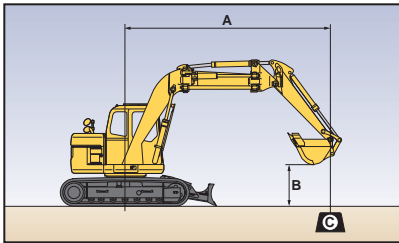

- Equipment:
- Arm: 2.13 m **7'0"**
 - Boom: 4.29 m **14'1"**
 - Bucket: 0.45 m³ **0.59 yd³**
- Blade is off ground

- A: Reach from swing center
- B: Bucket hook height
- C: Lifting capacity
- Cf: Rating over front
- Cs: Rating over side
- ⊗: Rating at maximum reach

Arm: 2130 mm 7'0" Shoe: 600 mm 24"		Unit: kg lb							
B	A	3.0 m 10'		4.6 m 15'		5.5 m 18'		⊗ Maximum	
		Cf	Cs	Cf	Cs	Cf	Cs	Cf	Cs
6.1 m 20'		*3550 *7,800	*3550 *7,800					*2700 *6,000	*2700 *6,000
3.0 m 10'		*5500 *12,100	4950 10,900	3400 7,500	2450 5,400	2400 5,300	1700 3,700	2200 4,900	1550 3,400
0.0 m 0'		5850 12,900	3700 8,200	2900 6,400	1950 4,300	2150 4,700	1450 3,200	1950 4,300	1350 3,000
-3.0 m -10'		2400 5,300	1650 3,600					2750 6,100	1850 4,100

KOMATSU®

Komatsu America International Company
440 N. Fairway Dr., Vernon Hills, IL 60061

